



**CZM**

FOUNDATION EQUIPMENT



**EK65**

EK65 ON CAT316F





# APPLICATION

The **EK65** from CZM has been designed for high performance and to have the fastest and easiest setup for operation and transport mode. It is a reliable drilling rig mounted on a CAT base, keeping the operation and maintenance extremely friendly and efficient.

This model is a very compact drill rig and the hydraulic functions in the cabin also allow the Kelly bar to follow the raising and lowering

of the mast, therefore the Kelly bar travels with the machine in a fast, easy and economic way.

The **EK65** also has the versatility to be easily converted from long to short mast by simply replacing the top mast assembly and Kelly bar.

## TECHNICAL SPECIFICATIONS

### KELLY BAR LONG MAST VERSION

Drilling Depth (Long - 5/92 ft; interlock kelly bar)	92 ft	28 m
Drilling Diameter (max. w/ boom up)	70 in	1,800 mm

### KELLY BAR SHORT MAST VERSION

Drilling Depth (Short - 5/41 ft; interlock kelly bar)	41 ft	12 m
Drilling Diameter (max. w/ boom up)	70 in	1,800 mm
Drilling Diameter (max. between tracks)	8 ft	2.44 m

### ROTARY HEAD

Max. torque (nominal)	57,000 lbf.ft	7,900 kgf.m
Working speed of rotation	11-33 rpm	11-33 rpm
Spin-off rotation	62 rpm	62 rpm

### CROWD SYSTEM

Cylinder stroke	5 ft	1,500 mm
Cylinder push force	25,000 lbf	11,300 kgf
Cylinder push speed	85 ft/min	26 m/min
Cylinder pull force	10,500 lbf	4,800 kgf
Cylinder pull speed	147 ft/min	45 m/min

### MAIN WINCH

Max. pull-force - 1st Layer (effective)	18,300 lbf	8,300 kgf
Line speed - 1st Layer	282 ft/min	86 m/min
Cable diameter	7/8"	22 mm
Drum diameter - 1st Layer	16.2 in	411 mm

### AUXILIARY WINCH\*

Max. pull-force - 1st Layer (effective)	4,400 lbf	2,000 kgf
Line speed - 1st Layer	125 ft/min	38 m/min
Cable diameter	1/2 in	12.7 mm
Drum diameter - 1st Layer	7.4 in	187 mm

### MAST INCLINATION

Backward	15°	15°
Forward	5°	5°
Sideways	7° / 7°	7° / 7°

\* Optional 6,600 lbf (3,000 kgf) winch available

### DIESEL ENGINE CAT316F TIER IV (CAT® C4.4 ACERT™)

Net Power – SAE J1349	117 hp	88 kW
Displacement	269 in <sup>3</sup>	4.4 L
Fuel Tank	76.6 gal	290L

### HYDRAULIC SYSTEM (CAT316F TIER IV)

Hydraulic pressure	5,076 psi	350 bar
Max. Flow (main circuit - 2 pumps)	79 gal/min	300 L/min
Max. Flow (auxiliary circuit)	14.3 gal/min	54 L/min
Pilot circuit pressure	580 psi	40 bar
Pilot circuit flow	6.8 gal/min	25.8 L/min
Hydraulic oil tank capacity	28 gal	106 L

### UNDERCARRIAGE

Track length	13 ft	3,970 mm
Length to Center of rollers	10 ft 5 in	3,170 mm
Transport position width (retracted)	8 ft 10 in	2,690 mm
Working position width (extended)	8 ft 10 in	2,690 mm
Shoes width	28 in	700 mm
Max. drawbar pull	35,115 lbf	15,600 kgf
Max. travel speed	3.2 mph	5.2 km/h

### TRANSPORT

Transport height	11 ft 10 in	3,600 mm
Length (Long Mast)	47 ft 5 in	14,500 mm
Length (Short Mast)	25 ft 3 in	7,700 mm
Transport width	8 ft 10 in	2,690 mm
Transport weight (long mast - kelly 5 / 92 ft)	60,000 lb	27,125 kg
Transport weight (short mast - kelly 5 / 41 ft)	55,000 lb	24,947 kg

### GENERAL DATA

Overall height (standard mast)	46 ft 7 in	14,200 mm
Overall height (short mast application)	24 ft 3 in	7,400 mm
(short mast application - w/ boom down)	18 ft 6 in	5,650 mm
Operation weight (standard mast)	61,700 lb	28,000 kg
Operation weight (short mast)	57,300 lb	26,000 kg

# GENERAL DIMENSIONS LONG MAST

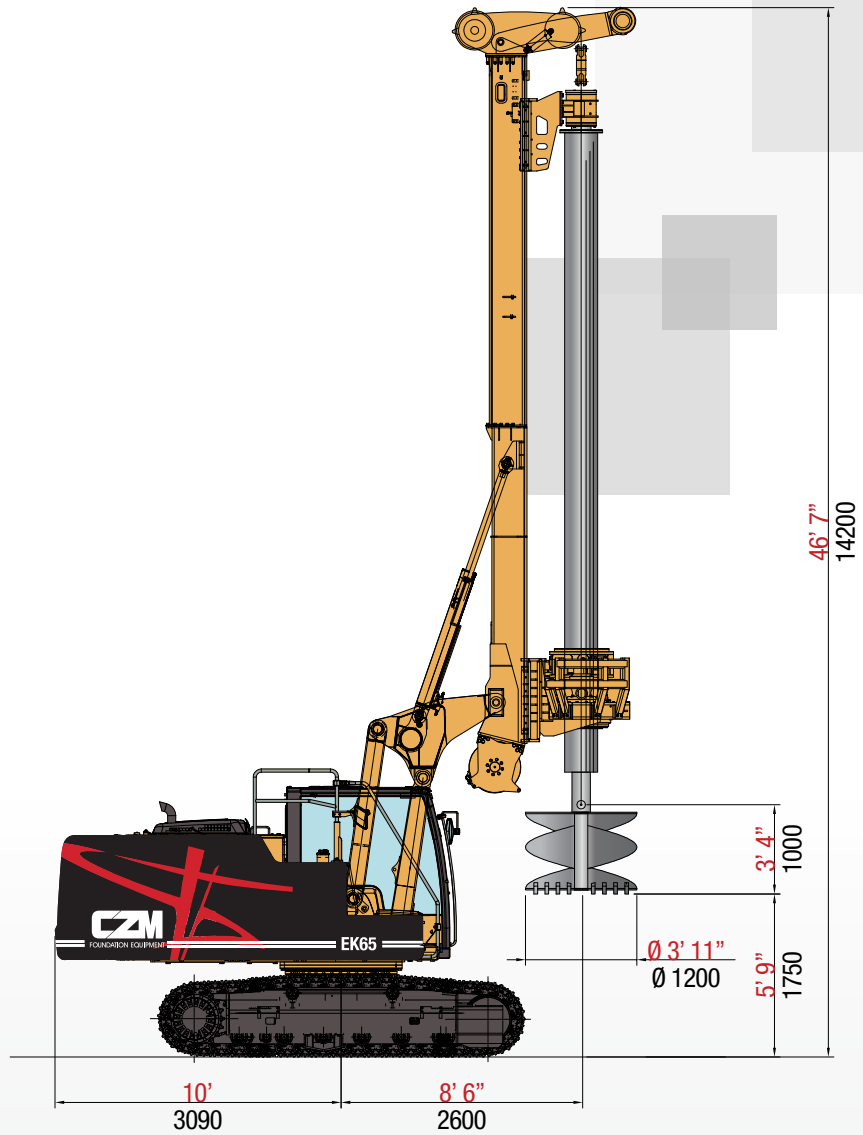

# TRANSPORT POSITION LONG MAST

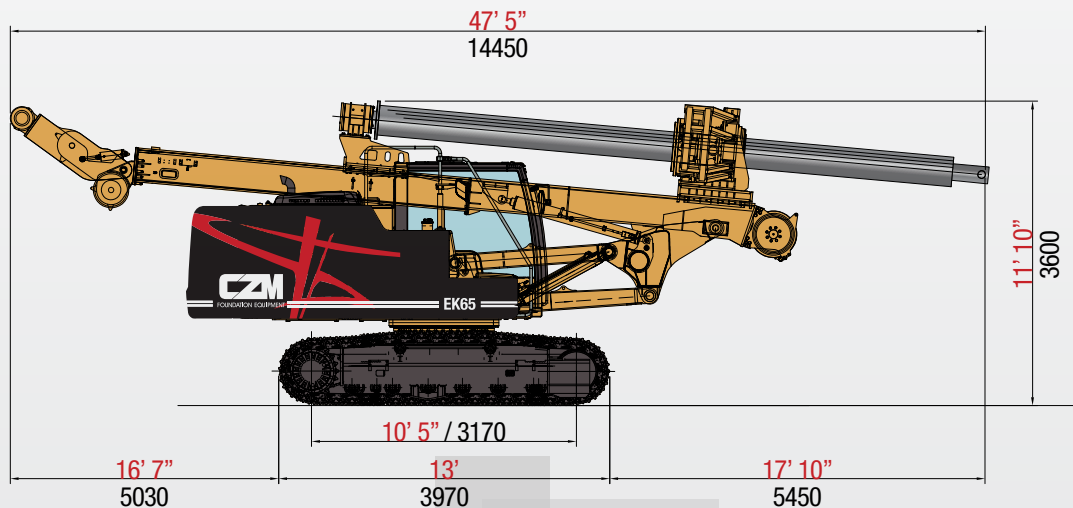



# SHORT MAST GENERAL DIMENSIONS

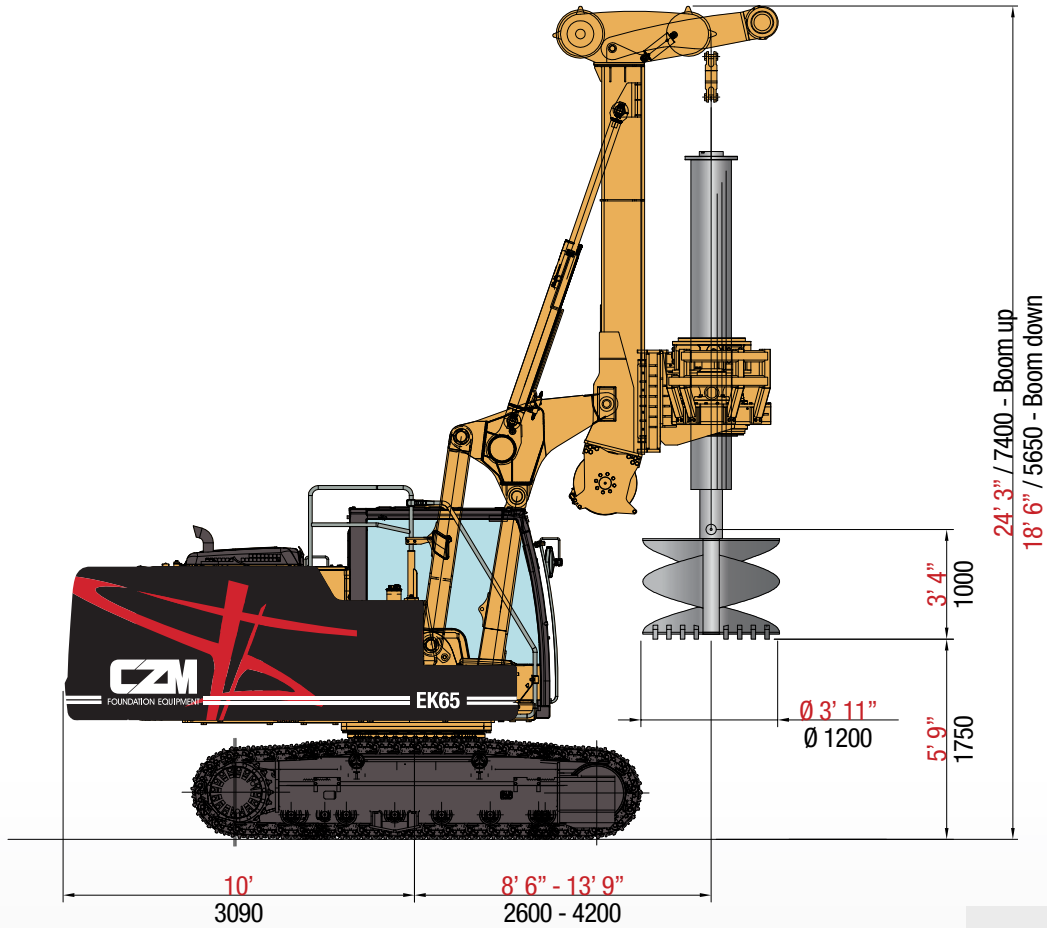

# TRANSPORT POSITION SHORT MAST

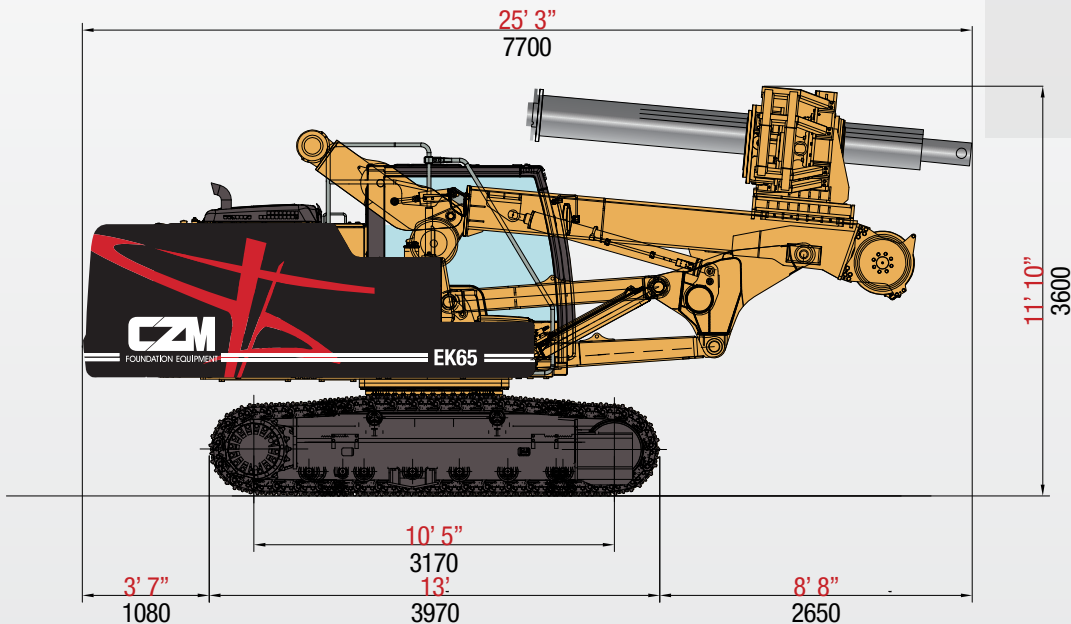









FOUNDATION EQUIPMENT

## THE COMPANY

CZM is headquartered in Savannah, Georgia, USA. For over 40 years, we have specialized in manufacturing foundation equipment. We design and customize models for many different drilling applications including Drill shafts, CFA/cased CFA, Micropile and anchoring, piledrive and hydraulic hammers and soil improvements. We are a Caterpillar OEM (Original Equipment Manufacturer).

### HEADQUARTERS

962 Interstate Centre Boulevard  
Ellabell • Georgia • 31308  
United States • Phone: (912) 200-7654

### AFTER SALES - GEORGIA

145 East Industrial Boulevard  
Pembroke • Georgia • 31321  
United States • Phone: (912) 200-7654

### AFTER SALES - TEXAS

2501 Blue Mound Rd. W  
Haslet • Texas • 76052  
United States • Phone: (817) 232-8053

[WWW.CZM-US.COM](http://WWW.CZM-US.COM)